

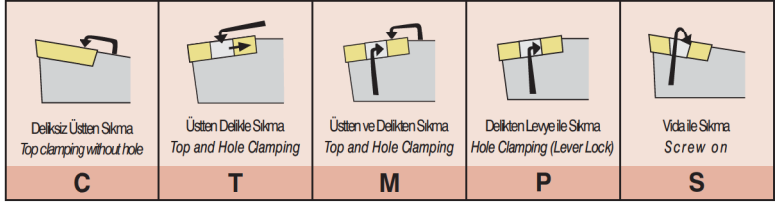

1 Sıkma Tipi / Method of Mounting of Insert

P **S** **K** **N** **R**

1 2 3 4 5



2 Uç Tipi / Insert Shape

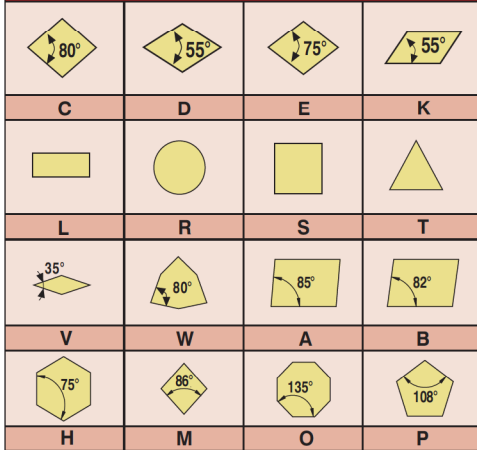

3 Yanaşma Açısı / ToolHolder Shape

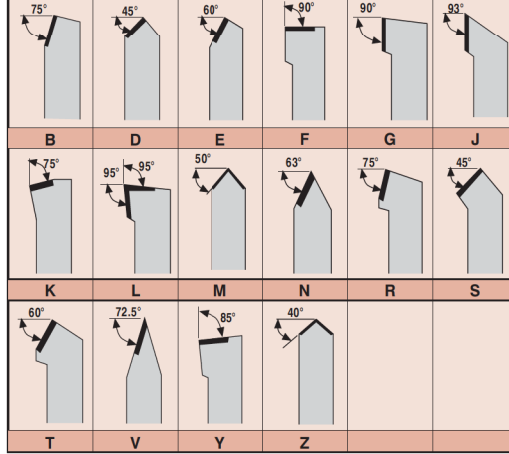

4 Serbest Uç Açısı / Clearance angle of Insert

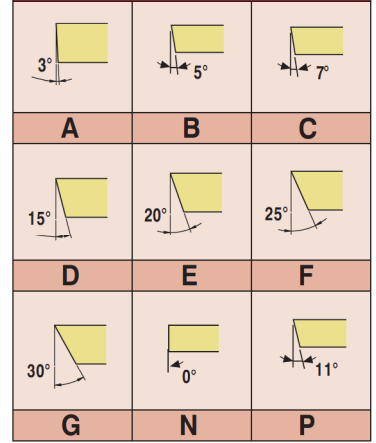

25 **25** - **M** **12** **C**

6 7 8 9 10

5 Kesme Yönü / Cutting Direction

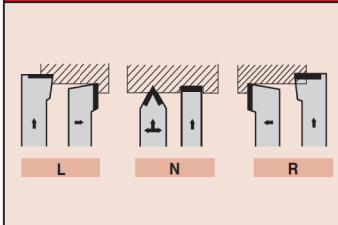

6 Kesme Kenar Yüksekliği / Cutting Edge Height

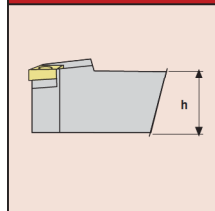

7 Şaft Genişliği / Shank Width

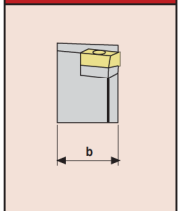

8 Şaft Boyu / Shank Length

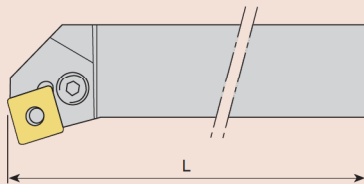

(mm)

A - 32	H - 100	Q - 180	x-special
B - 40	J - 110	R - 200	
C - 50	K - 125	S - 250	
D - 60	L - 140	T - 300	
E - 70	M - 150	U - 350	
F - 80	N - 160	V - 400	
G - 90	P - 170	W - 450	

9 Kesme Kenar Uzunluğu / Cutting Edge Length

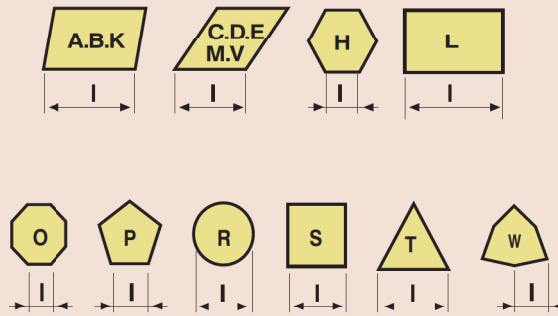

10 Baskı Pabucu / Wedge Clamp

